

## **WIRELESS RC HELICOPTER INSTRUCTION MANUAL**

# **9051**

### **Important**

Products are used gyroscope technology, the use of the former method of operation by the following:

1. the remote control power switch "ON" position, after burning the throttle to operate under the minimum drag.
2. the plane of the power cord properly connected, the power switch "ON" position, the aircraft on the formation of a smooth surface, keep the aircraft at this time in a static state, 5 seconds after the end gyroscope check so that you can the correct flight.

## INCLUDED PARTS NAME:

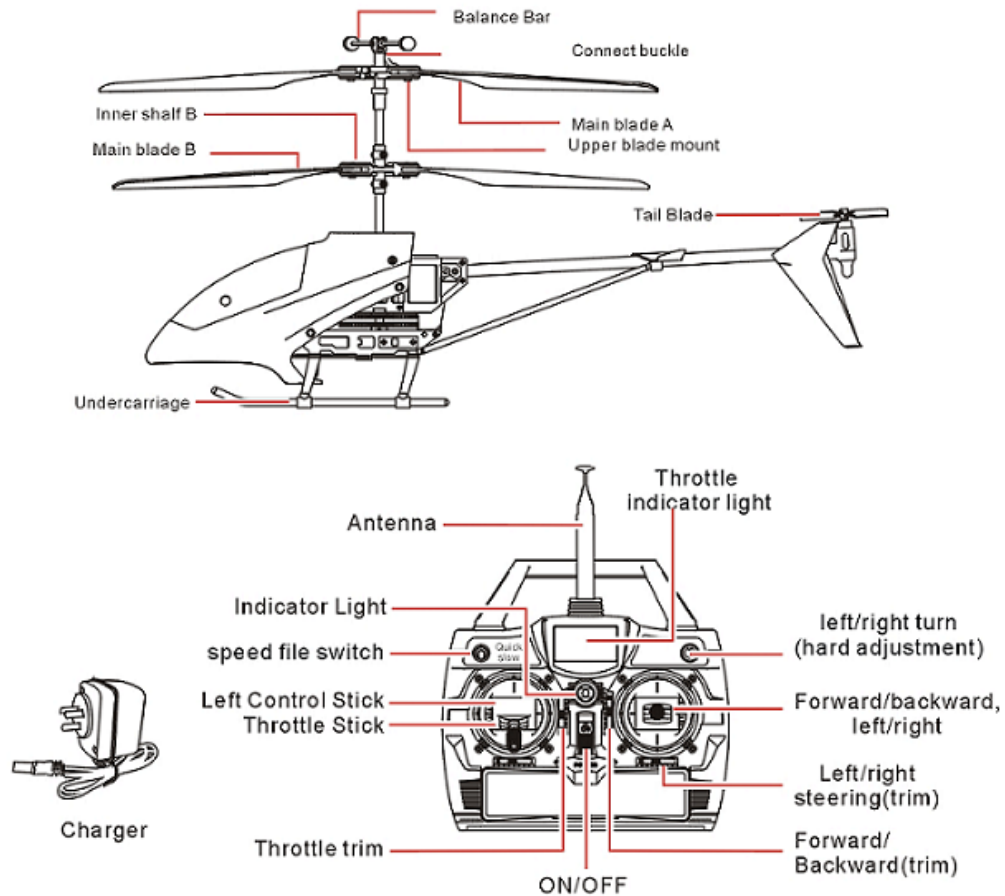

## ASSEMBLY TRANSMITTER

1. Install antenna cord: remove antenna into adapter clockwise.
2. Install batteries: open the cover of battery case, insert 8 batteries (size 1.5V AA) properly followed by polar indicator. (batteries to be purchased).

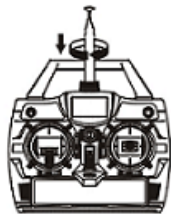

Fig.1

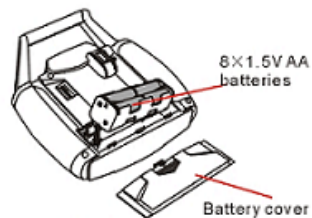

Fig.2

### NOTICE:

1. Install the battery must recognize the battery and battery box is precise
2. do not mix new and old batteries together when in use.
3. Please don't mix different types of batteries when in use

## CHARGE BATTERIES OF CHOPPER BODY

Unplug battery and wires from the circuit board, and then connect battery with adapter, plug adapter to 110V/220V power outlet. It begins to charge.

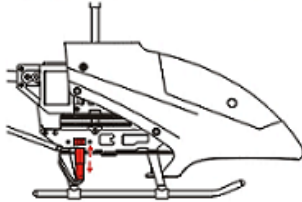

NOTES: Be sure the adapter fit your local electrical Power supply.

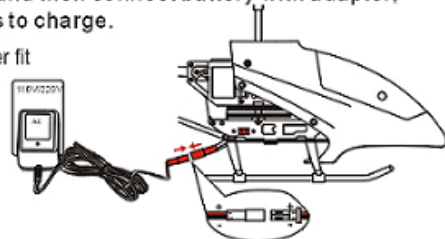

Make sure the helicopter switch is on "OFF" position before charge, remove the adapter, connect the adapter to the local power, just then, the indicator light of a adapter will light up (special requirements without lights, about 180 minutes of charging), then gently plug the electric wire of charge into the small faucet under the helicopter. (as shown) Note: can only be connected one way, do not force to connect them all together, you should connect each parts carefully. When connect the helicopter with charger, the indicator light of a adapter is dark, it means that is charging. If the helicopter are fully recharge and charge once more, the indicator light cannot dark, moreover cannot continue to charge. When the indicator light is Bright, it means that charging is completed. Unplug pontes of the electric wire of charge on the helicopter.

## INSTALL THE BATTERY

Connect the battery and the tie-in of circuit board, and can't installation reverse the polarity.

### WARNING ⚠

1. If the helicopter flight time, please dial to the OFF to switch off to prevent battery discharge.
2. Please disconnect the battery pack connector to the battery box of the helicopter if it is not in use. Otherwise, it may leak.

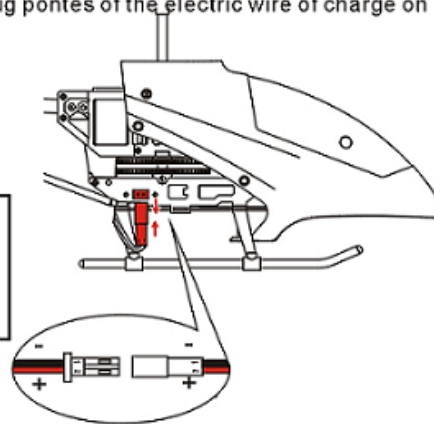





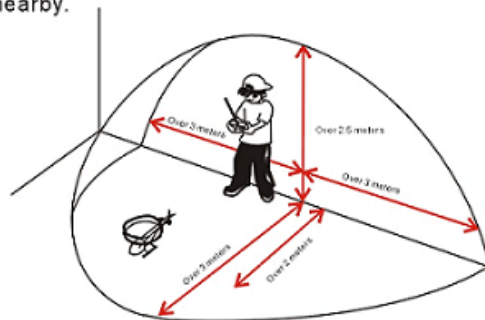

## ENVIRONMENT FOR FLIGHT:

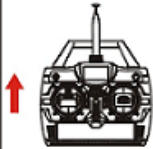
1. Fly on a sunny day, without wind.
  - ① Do not fly in extreme temperature.  
Do not fly in temperature above 113 degrees fahrenheit/45 degrees centigrade, or below 50 degrees fahrenheit/10 degrees centigrade.  
Flying in extreme heat and/of cold will affect performance and may damage the model.
  - ② Do not fly in strong wind.  
Windy conditions will limit, or disturb the flying control.  
In very windy conditions, your helicopter may become lost and/or damaged.
2. Select a large, wide-open area for flying, and make sure that there is no obstructions, animals or people nearby.

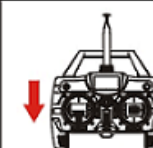

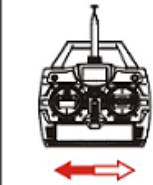
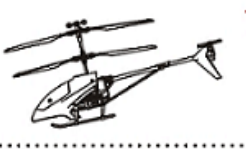
## CONTROL METHOD

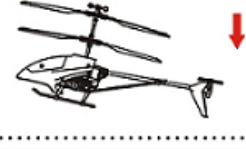
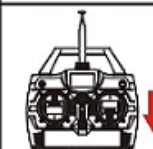
Ascend	When you push up the left stick (throttle stick,)the spinning speed of the main rotor blade is increase and the helicopter begin to ascend.		
Descend	When you pull down the left stick (throttle stick,)the spinning speed of the main rotor blade is decrease and the helicopter begin to descend.		
Steering	1. When the right stick (rudder stick) is moving to left, the head of the helicopter turns to left. 2. When the right stick (rudder stick) is moving to right, the head of the helicopter turns to right.		
Forward	When you push up the right control lever (steering rudder), the nose incline to down, the helicopter is moving to forward.		
Backward	When you push down the right control lever (steering rudder), the nose incline to up, the helicopter is moving to backward..		

## SPECIAL PROMPT

If helicopter flies, rotating in the air without pulling control stick, then you can stop the fly, use screw driver to adjust the potentiometer on chopper circuit board lightly till it is steady. After adjust the trim button but yet revolving, you should be turn the trim to the center position, then adjust the hard adjustment till it stop revolving.

### NOTICE:

When the airplane away from the ground in 30cm position, the helicopter will suffer by itself blade vortex to become unstable, we call it "effect response", when the helicopter weight lower, and the "effect response" affect will be bigger.

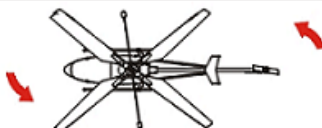
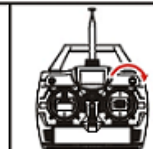
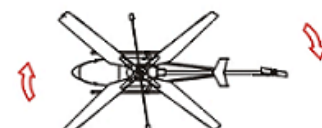
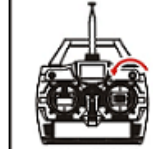
When the helicopter is turning to left, please push the rudder trim to right slowly until the helicopter is still.		
When the helicopter is turning to right, please push the rudder trim to left slowly until the helicopter is still.		

## FLYING PRACTICE

After the enough practice, you can attempts following flying practice.



Fixed revolves  
(direction revolve)

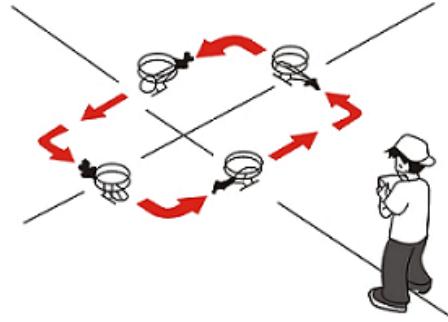

Always go forward and turn left ,and exercise flight in a quadrate pattern, then repeatedly practices to gradual practice flight in a rotundity.

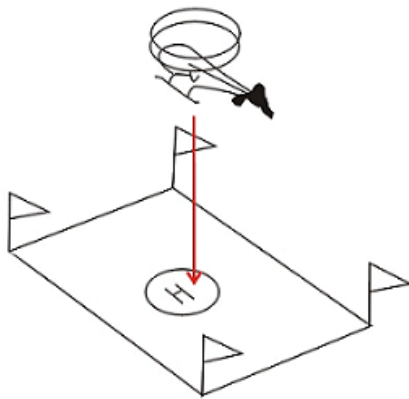

Landing at the appoint  
pace (fixed landing)



(number 8 flight)

## TROUBLE SHOOT AND DEALING WITH

PROBLEM	CAUSE	CHECK THIS
Controller doesn't work	1. Controller's power switch is off.	1. Turn power switch on.
	2. Insert batteries into controller improperly.	2. Confirm batteries be inserted according to their pole.
	3. Batteries lack of power.	3. Change new batteries instead.
Can not control the helicopter	1. You haven't operated the controller.	1. Turn controller power switch on.
	2. Doesn't turn on controller's power switch.	2. Turn helicopter's power switch on.
	3. Doesn't wrest antenna into controller completely, or antenna isn't fully pulled out.	3. Wrest antenna completely and pull it out.
	4. You play the helicopter in strong winds weather.	4. Do not play the chopper in winds, which can confuse your control.
	5. The indicator light of controller is twinkle.	5. Pulling the power control rod upwards, then again return to pulling to the lowest, or change battery.
Helicopter can not rise	1. Main rotor blades rotate too slowly.	1. Pull up the throttle stick.
	2. Doesn't fully charge helicopter's battery.	2. Full charge helicopter battery. ( see instruction above)
Helicopter land too fast.	You loose the throttle stick or pull it down too fast.	Slowly pull down the throttle till the chopper landing smoothly.

### CAUTION

1. The control distance will shorter when the quantity of electricity is not full.
2. When the quantity of the electricity of the helicopter is not full, the helicopter will launch difficultly or the height of fly is not enough.
3. If the helicopter become damaged, deformation, please repaired in time.  
If the rotor become damaged or broken, do not fly, otherwise, it will lead to injury.
4. If you don't use the transmitter for a long time. Remove all batteries out, in order to avoid the battery leakage to damage this product.
5. Don't drop the helicopter from high position or crash it seriously, because that will damage it seriously or shorten the using time.
6. Before flight, always turn on the power switch on the controller and then turnon helicopter, Otherwise the radio signals of helicopter will be in confusion.
7. After flight, always turn off the power switch on the helicopter and then turn off the controller, Otherwise the radio signals of helicopter will be mixed up and you will lose control to your model.

**PARTS ARE ALTERNATIVE**



Balance Bar unit

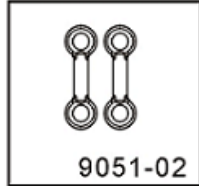

Connect buckle

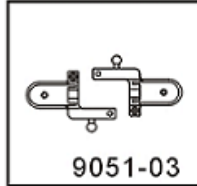

Upper blade mount

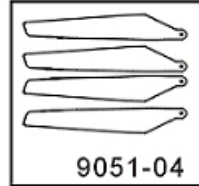

Main blade AB

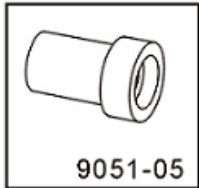

Bearing set collar

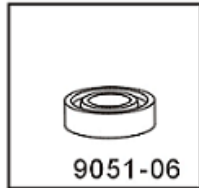

Bearing  
5×25×1.5

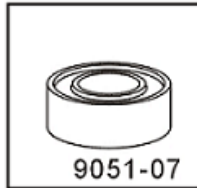

Bearing(7×4×2)



bushing fixing set  
8×4×3.3

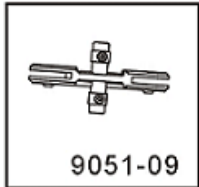

Lower blade mount

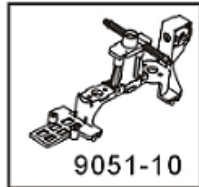

Main frame unit

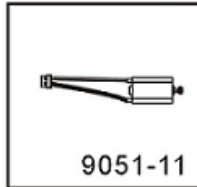

A blade main  
motor unit

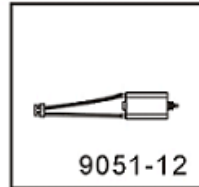

B blade main  
motor unit

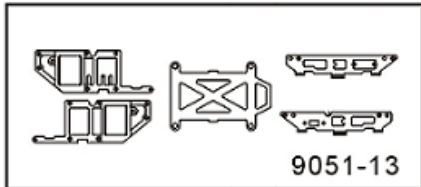

Main frame decorated aluminium plates

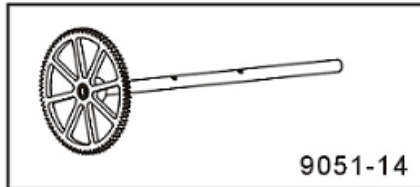

Gear set



Lower Gear

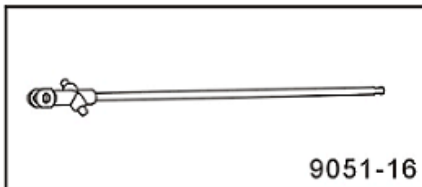

Inner shaft

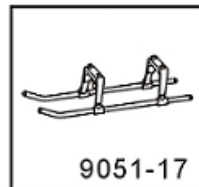

Undercarriage

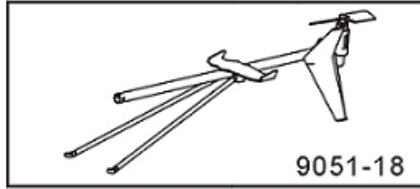

9051-18

Chopper Tail Unit



9051-19

Tail Blade

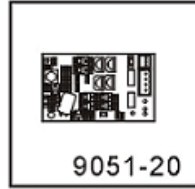

9051-20

PCB

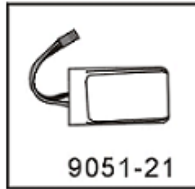

9051-21

Lithium-ion polymer battery

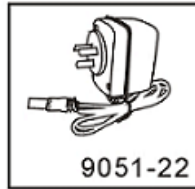

9051-22

Charger

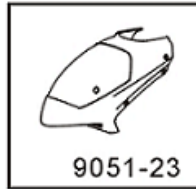

9051-23

Head Cover unit